

Technical data

LE21GT

TEUPEN[®]
...access redefined

since '77

PERFORMANCE

Working height, max.	21,00 m
Platform height, max.	19,00 m
Horizontal outreach, max. (250 kg)	12,00 m
Up and over clearance, max.	9,44 m
Platform capacity, max.	250 kg
Jib, movable	-
Platform, rotatable	180 °
Turntable rotation, max.	450 °
To be jacked up on ground slope of	19,0 ° / 34,0 %
Track drive, height- and width-adjustable	19 / 46 cm
Gradeability, max.	16,7 ° / 30,0 %
Slope angle, max.	19,0 ° / 34,0 %
Travel speed, max.	2,0 km/h

MEASUREMENTS*

Platform (height) (A)	1,10 m
Platform (length) (B)	1,40 m
Platform (width) (C)	0,70 m
Length (D)	6,40 m
Length without platform (E)	5,05 m
Height (F)	1,99 m
Width, min. (G)	0,98 m
Ground clearance, max. (H)	0,44 m
Track (length x width) (I)	1,45 x 0,20 m
Outrigger footprint both side wide (length) (J)	4,70 m
Outrigger footprint both side wide (width) (K)	4,70 m
Outrigger footprint one side narrow (length) (L)	6,30 m
Outrigger footprint one side narrow (width) (M)	3,65 m
Outrigger footprint both sides narrow (width) (N)	2,65 m
Outrigger plate Ø	0,18 m

WEIGHT*

Total weight	3000 kg
Live load in travelling position	4,64 kN/m ²
Live load in working position	1,57 kN/m ²
Point load per outrigger plate, max.	23,70 kN

POWER SOURCES

Standard power sources:

■ Electric motor	(230 V, 12,9 A, 2,2 kW)
■ Combustion engine (petrol)	Vanguard OHV 16HP (11,93 kW / 16,0 hp)

Optional power source:

■ Combustion engine (Diesel)	Kubota Z602 (10,8 kW / 14,5 hp)
■ Battery drive (lead acid)	48 V

Fuel tank capacity (petrol engine)	11,5 l
Fuel tank capacity (Diesel engine)	11,5 l

POWER SUPPLY

Electric current, max.	230 V / 16 A
------------------------	--------------

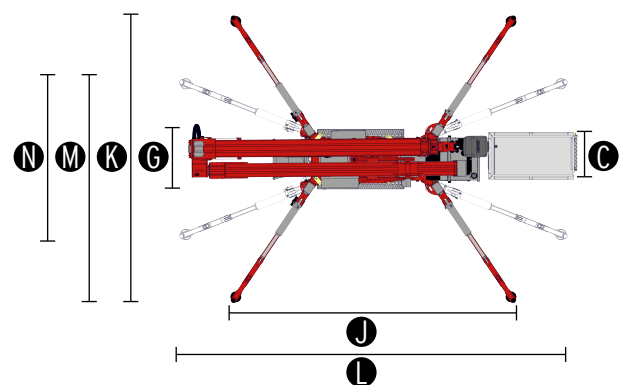
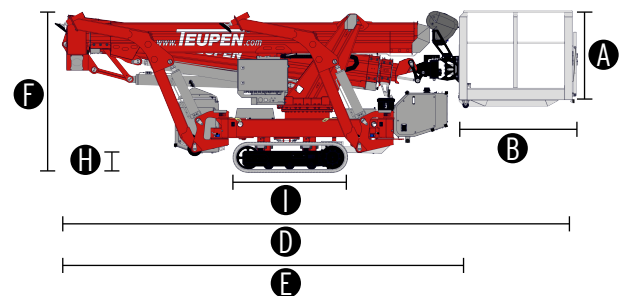
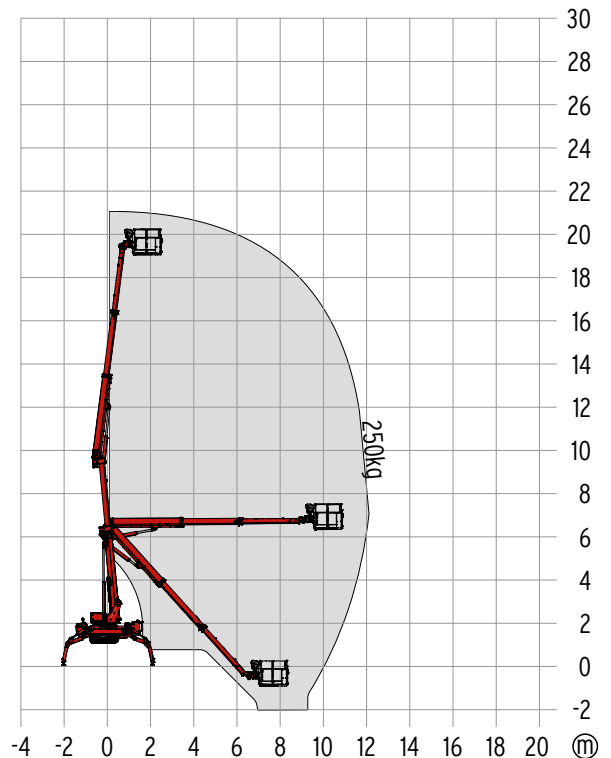

STANDARDS

2006/42/EG-Machinery directive
(Harmonised standard EN280:2013); 2004/108/EG (EMV);
2000/14/EG (Noise emission directive)

* The technical data may deviate +/- 3% from the specified values.
* Weight and dimensions may vary depending on options and accessories.

CHASSIS

- Powerful track drive with hydraulic braking system
- Precise manoeuvring via sensitive, electro hydraulic control panel
- Indoor non-marking rubber tracks, with less tread depth the profile enables smooth travelling
- Hydraulically height- and width-adjustable crawler track drive

STABILISATION

- Electrohydraulic stabilisation with automatic levelling and ground pressure sensor system
- Variable outrigger system with one side or both sides narrow setup option
- Wear resistant, ant-friction outrigger pads

BOOM SYSTEM

- Telescopic lower and upper boom
- All functions available from the platform
- Stepless, electrical proportional control system with intuitive operation
- Robust, lockable control panel
- Parallel guided platform with electro hydraulic levelling
- Corner mounted, 180° rotatable platform for extra flexibility
- Turntable rotation via high-performance slewing ring, worm gear and hydraulic motor

POWER SOURCE

- Electric motor (230 V, 12,9 A, 2,2 kW)
- Petrol engine Vanguard OHV 16HP (11,93 kW / 16,0 hp)
- Start-stop device for combustion engine in the platform

PRODUCTIVITY, SAFETY, QUALITY

- Hydraulic emergency lowering via hand pump
- Power socket in the platform (110 V / 16 A)
- Detachable platform, attachment points for safety harnesses and tool tray
- Drive operation without platform possible
- Protected, internal power track for platform control
- Hydraulic system filled with biodegradable hydraulic oil
- High-quality paint in RAL 3020 (red)
 - Hydraulic cylinders in RAL 9006 (white aluminum)
 - Engine unit & component support in RAL 9006 (white aluminum)
- Unlockable check valves located directly on hydraulic cylinders
- Hydraulic system protected by pressure relief valves
- Hydraulic tank, emergency control, connecting cables and hoses are mounted protected
- Cable remote control as complete control panel for bottom connection, including storage box
- Display in the control panel
- Hour meter
- Fuzzy control technology

OPTIONS*

- Diesel engine Kubota Z602 (10,8 kW / 14,5 hp)
- Battery drive 48 V (lead acid) including charging device
- Custom paintwork, one colour, according to RAL scheme
 - (except metallic coatings, signal- or special colours)
- Custom paintwork, two colours, according to RAL scheme
 - (except metallic coatings, signal- or special colours)
- Radio remote control
- White, non-marking rubber tracks with specially arranged profile for optimal grip
- Water and air connection, platform

ACCESSORIES*

- Safety harness
- 4 sliding pads (700 x 220 x 60 mm)
- 2 protective track covers made of high-quality polypropylene fabric
- Track mat (2000 x 800 x 15 mm)
- Lifting device (300 kg capacity)
 - Only in combination with platform ladder monitoring system
- 4 covers, piston rod (outrigger)
- Tree package, including
 - Cover (control box, turntable)
 - 4 covers, piston rod (outrigger)
- 2 LED headlights (combustion engine)
- 2 LED headlights (battery drive)
- Platform (900 x 800 mm)
- Coming home function - automatic return of the boom into transport position
- Platform ladder monitoring system with boom function cut-off
- Emergency lowering via electric pump, including additional hydraulic drive (12 V) for boom recovery via platform control
- TOP level 1

TRAILER OR SUBFRAME

- Tandem low platform trailer (aluminium)
 - Maximum permissible weight (3,5 t)
 - Net weight (460 kg)
 - Payload (3040 kg)
- Subframe for truck Mitsubishi Canter (7,5 t)
 - Net weight subframe (450 kg)
- Subframe for truck Mercedes Atego (10,0 t)
 - Net weight subframe (450 kg)
- Subframe for truck Mercedes Atego (12,0 t)
 - Net weight subframe (460 kg)

CONTACT

TEUPEN Maschinenbau GmbH
Marie-Curie-Str.13
48599 Gronau
Germany

Phone +49 2562 8161-0
Fax +49 2562 8161-888
E-mail mail@teupen.com

* Weight and dimensions may vary depending on options and accessories.

Product specifications are subject to change without notice or obligation. Photographs and drawings in this document are for illustrative purposes only. Refer to the appropriate Operator's Manual for instructions on the proper use of this equipment. Failure to follow the appropriate Operator's Manual when using our equipment or to otherwise act irresponsibly may result in serious injury or death. The only warranty applicable to our equipment is the standard written warranty applicable to the particular product and sale and we make no other warranty, expressed or implied. Products and services listed may be trademarks, service marks or trade-names of TEUPEN Maschinenbau GmbH and/or its subsidiaries in the U.S.A. and many other countries. "TEUPEN", "Access redefined" and "LEO Series" are registered Trademarks of Teupen GmbH in the United States of America and many other countries. © 2020 TEUPEN Maschinenbau GmbH.



2021-A_en_GB