

Mobiflex 200-M

When assembling a new package
start with this manual.

Safety Depends on You

Lincoln arc welding and cutting equipment is designed and built with safety in mind. However, your overall safety can be increased by proper installation ... and thoughtful operation on your part. **DO NOT INSTALL, OPERATE OR REPAIR THIS EQUIPMENT WITHOUT READING THIS MANUAL AND THE SAFETY PRECAUTIONS CONTAINED THROUGHOUT.** And, most importantly, think before you act and be careful.

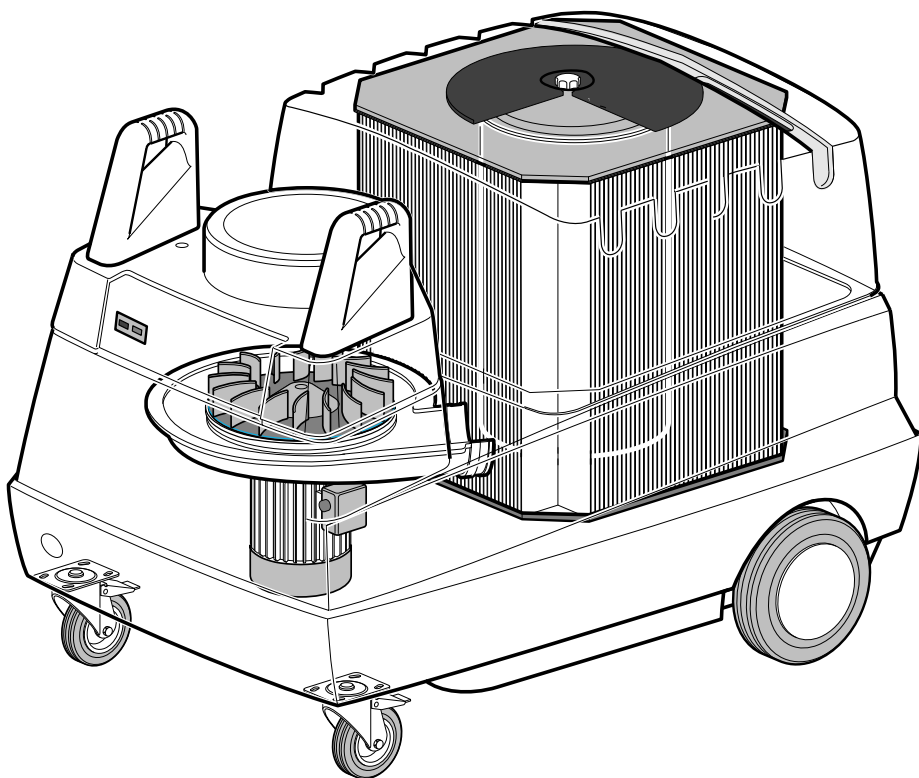

OPERATOR'S MANUAL

LINCOLN[®]
ELECTRIC

Copyright © Lincoln Global Inc.

• World's Leader in Welding and Cutting Products •

• Sales and Service through Subsidiaries and Distributors Worldwide •

Cleveland, Ohio 44117-1199 U.S.A. TEL: 216.481.8100 FAX: 216.486.1751 WEB SITE: www.lincolnelectric.com

⚠ WARNING

⚠ CALIFORNIA PROPOSITION 65 WARNINGS ⚠

Diesel engine exhaust and some of its constituents are known to the State of California to cause cancer, birth defects, and other reproductive harm.

The Above For Diesel Engines

The engine exhaust from this product contains chemicals known to the State of California to cause cancer, birth defects, or other reproductive harm.

The Above For Gasoline Engines

ARC WELDING CAN BE HAZARDOUS. PROTECT YOURSELF AND OTHERS FROM POSSIBLE SERIOUS INJURY OR DEATH. KEEP CHILDREN AWAY. PACEMAKER WEARERS SHOULD CONSULT WITH THEIR DOCTOR BEFORE OPERATING.

Read and understand the following safety highlights. For additional safety information, it is strongly recommended that you purchase a copy of "Safety in Welding & Cutting - ANSI Standard Z49.1" from the American Welding Society, P.O. Box 351040, Miami, Florida 33135 or CSA Standard W117.2-1974. A Free copy of "Arc Welding Safety" booklet E205 is available from the Lincoln Electric Company, 22801 St. Clair Avenue, Cleveland, Ohio 44117-1199.

BE SURE THAT ALL INSTALLATION, OPERATION, MAINTENANCE AND REPAIR PROCEDURES ARE PERFORMED ONLY BY QUALIFIED INDIVIDUALS.



FOR ENGINE powered equipment.

1.a. Turn the engine off before troubleshooting and maintenance work unless the maintenance work requires it to be running.



1.b. Operate engines in open, well-ventilated areas or vent the engine exhaust fumes outdoors.



1.c. Do not add the fuel near an open flame welding arc or when the engine is running. Stop the engine and allow it to cool before refueling to prevent spilled fuel from vaporizing on contact with hot engine parts and igniting. Do not spill fuel when filling tank. If fuel is spilled, wipe it up and do not start engine until fumes have been eliminated.

1.d. Keep all equipment safety guards, covers and devices in position and in good repair. Keep hands, hair, clothing and tools away from V-belts, gears, fans and all other moving parts when starting, operating or repairing equipment.

1.e. In some cases it may be necessary to remove safety guards to perform required maintenance. Remove guards only when necessary and replace them when the maintenance requiring their removal is complete. Always use the greatest care when working near moving parts.



1.f. Do not put your hands near the engine fan. Do not attempt to override the governor or idler by pushing on the throttle control rods while the engine is running.

1.g. To prevent accidentally starting gasoline engines while turning the engine or welding generator during maintenance work, disconnect the spark plug wires, distributor cap or magneto wire as appropriate.



1.h. To avoid scalding, do not remove the radiator pressure cap when the engine is hot.



ELECTRIC AND MAGNETIC FIELDS may be dangerous

2.a. Electric current flowing through any conductor causes localized Electric and Magnetic Fields (EMF). Welding current creates EMF fields around welding cables and welding machines

2.b. EMF fields may interfere with some pacemakers, and welders having a pacemaker should consult their physician before welding.

2.c. Exposure to EMF fields in welding may have other health effects which are now not known.

2.d. All welders should use the following procedures in order to minimize exposure to EMF fields from the welding circuit:

2.d.1. Route the electrode and work cables together - Secure them with tape when possible.

2.d.2. Never coil the electrode lead around your body.

2.d.3. Do not place your body between the electrode and work cables. If the electrode cable is on your right side, the work cable should also be on your right side.

2.d.4. Connect the work cable to the workpiece as close as possible to the area being welded.

2.d.5. Do not work next to welding power source.



ELECTRIC SHOCK can kill.

3.a. The electrode and work (or ground) circuits are electrically “hot” when the welder is on. Do not touch these “hot” parts with your bare skin or wet clothing. Wear dry, hole-free gloves to insulate hands.

3.b. Insulate yourself from work and ground using dry insulation. Make certain the insulation is large enough to cover your full area of physical contact with work and ground.

In addition to the normal safety precautions, if welding must be performed under electrically hazardous conditions (in damp locations or while wearing wet clothing; on metal structures such as floors, gratings or scaffolds; when in cramped positions such as sitting, kneeling or lying, if there is a high risk of unavoidable or accidental contact with the workpiece or ground) use the following equipment:

- Semiautomatic DC Constant Voltage (Wire) Welder.
- DC Manual (Stick) Welder.
- AC Welder with Reduced Voltage Control.

3.c. In semiautomatic or automatic wire welding, the electrode, electrode reel, welding head, nozzle or semiautomatic welding gun are also electrically “hot”.

3.d. Always be sure the work cable makes a good electrical connection with the metal being welded. The connection should be as close as possible to the area being welded.

3.e. Ground the work or metal to be welded to a good electrical (earth) ground.

3.f. Maintain the electrode holder, work clamp, welding cable and welding machine in good, safe operating condition. Replace damaged insulation.

3.g. Never dip the electrode in water for cooling.

3.h. Never simultaneously touch electrically “hot” parts of electrode holders connected to two welders because voltage between the two can be the total of the open circuit voltage of both welders.

3.i. When working above floor level, use a safety belt to protect yourself from a fall should you get a shock.

3.j. Also see Items 6.c. and 8.



ARC RAYS can burn.

4.a. Use a shield with the proper filter and cover plates to protect your eyes from sparks and the rays of the arc when welding or observing open arc welding. Headshield and filter lens should conform to ANSI Z87.1 standards.

4.b. Use suitable clothing made from durable flame-resistant material to protect your skin and that of your helpers from the arc rays.

4.c. Protect other nearby personnel with suitable, non-flammable screening and/or warn them not to watch the arc nor expose themselves to the arc rays or to hot spatter or metal.



FUMES AND GASES can be dangerous.

5.a. Welding may produce fumes and gases hazardous to health. Avoid breathing these fumes and gases. When welding, keep your head out of the fume. Use enough ventilation and/or exhaust at the arc to keep

fumes and gases away from the breathing zone. **When welding with electrodes which require special ventilation such as stainless or hard facing (see instructions on container or MSDS) or on lead or cadmium plated steel and other metals or coatings which produce highly toxic fumes, keep exposure as low as possible and within applicable OSHA PEL and ACGIH TLV limits using local exhaust or mechanical ventilation. In confined spaces or in some circumstances, outdoors, a respirator may be required. Additional precautions are also required when welding on galvanized steel.**

5. b. The operation of welding fume control equipment is affected by various factors including proper use and positioning of the equipment, maintenance of the equipment and the specific welding procedure and application involved. Worker exposure level should be checked upon installation and periodically thereafter to be certain it is within applicable OSHA PEL and ACGIH TLV limits.

5.c. Do not weld in locations near chlorinated hydrocarbon vapors coming from degreasing, cleaning or spraying operations. The heat and rays of the arc can react with solvent vapors to form phosgene, a highly toxic gas, and other irritating products.

5.d. Shielding gases used for arc welding can displace air and cause injury or death. Always use enough ventilation, especially in confined areas, to insure breathing air is safe.

5.e. Read and understand the manufacturer’s instructions for this equipment and the consumables to be used, including the material safety data sheet (MSDS) and follow your employer’s safety practices. MSDS forms are available from your welding distributor or from the manufacturer.

5.f. Also see item 1.b.

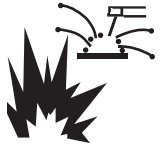

WELDING and CUTTING SPARKS can cause fire or explosion.

6.a. Remove fire hazards from the welding area. If this is not possible, cover them to prevent the welding sparks from starting a fire.

Remember that welding sparks and hot materials from welding can easily go through small cracks and openings to adjacent areas. Avoid welding near hydraulic lines. Have a fire extinguisher readily available.

- 6.b. Where compressed gases are to be used at the job site, special precautions should be used to prevent hazardous situations. Refer to "Safety in Welding and Cutting" (ANSI Standard Z49.1) and the operating information for the equipment being used.
- 6.c. When not welding, make certain no part of the electrode circuit is touching the work or ground. Accidental contact can cause overheating and create a fire hazard.
- 6.d. Do not heat, cut or weld tanks, drums or containers until the proper steps have been taken to insure that such procedures will not cause flammable or toxic vapors from substances inside. They can cause an explosion even though they have been "cleaned". For information, purchase "Recommended Safe Practices for the Preparation for Welding and Cutting of Containers and Piping That Have Held Hazardous Substances", AWS F4.1 from the American Welding Society (see address above).
- 6.e. Vent hollow castings or containers before heating, cutting or welding. They may explode.
- 6.f. Sparks and spatter are thrown from the welding arc. Wear oil free protective garments such as leather gloves, heavy shirt, cuffless trousers, high shoes and a cap over your hair. Wear ear plugs when welding out of position or in confined places. Always wear safety glasses with side shields when in a welding area.
- 6.g. Connect the work cable to the work as close to the welding area as practical. Work cables connected to the building framework or other locations away from the welding area increase the possibility of the welding current passing through lifting chains, crane cables or other alternate circuits. This can create fire hazards or overheat lifting chains or cables until they fail.
- 6.h. Also see item 1.c.
- 6.i. Read and follow NFPA 51B "Standard for Fire Prevention During Welding, Cutting and Other Hot Work", available from NFPA, 1 Batterymarch Park, PO box 9101, Quincy, Ma 022690-9101.
- 6.j. Do not use a welding power source for pipe thawing.



CYLINDER may explode if damaged.

- 7.a. Use only compressed gas cylinders containing the correct shielding gas for the process used and properly operating regulators designed for the gas and pressure used. All hoses, fittings, etc. should be suitable for the application and maintained in good condition.
- 7.b. Always keep cylinders in an upright position securely chained to an undercarriage or fixed support.
- 7.c. Cylinders should be located:
 - Away from areas where they may be struck or subjected to physical damage.
 - A safe distance from arc welding or cutting operations and any other source of heat, sparks, or flame.
- 7.d. Never allow the electrode, electrode holder or any other electrically "hot" parts to touch a cylinder.
- 7.e. Keep your head and face away from the cylinder valve outlet when opening the cylinder valve.
- 7.f. Valve protection caps should always be in place and hand tight except when the cylinder is in use or connected for use.
- 7.g. Read and follow the instructions on compressed gas cylinders, associated equipment, and CGA publication P-1, "Precautions for Safe Handling of Compressed Gases in Cylinders," available from the Compressed Gas Association 1235 Jefferson Davis Highway, Arlington, VA 22202.



FOR ELECTRICALLY powered equipment.

- 8.a. Turn off input power using the disconnect switch at the fuse box before working on the equipment.
- 8.b. Install equipment in accordance with the U.S. National Electrical Code, all local codes and the manufacturer's recommendations.
- 8.c. Ground the equipment in accordance with the U.S. National Electrical Code and the manufacturer's recommendations.

Refer to <http://www.lincolnelectric.com/safety> for additional safety information.

PRÉCAUTIONS DE SÛRETÉ

Pour votre propre protection lire et observer toutes les instructions et les précautions de sûreté spécifiques qui paraissent dans ce manuel aussi bien que les précautions de sûreté générales suivantes:

Sûreté Pour Soudage A L'Arc

1. Protégez-vous contre la secousse électrique:
 - a. Les circuits à l'électrode et à la pièce sont sous tension quand la machine à souder est en marche. Eviter toujours tout contact entre les parties sous tension et la peau nue ou les vêtements mouillés. Porter des gants secs et sans trous pour isoler les mains.
 - b. Faire très attention de bien s'isoler de la masse quand on soude dans des endroits humides, ou sur un plancher métallique ou des grilles métalliques, principalement dans les positions assis ou couché pour lesquelles une grande partie du corps peut être en contact avec la masse.
 - c. Maintenir le porte-électrode, la pince de masse, le câble de soudage et la machine à souder en bon et sûr état de fonctionnement.
 - d. Ne jamais plonger le porte-électrode dans l'eau pour le refroidir.
 - e. Ne jamais toucher simultanément les parties sous tension des porte-électrodes connectés à deux machines à souder parce que la tension entre les deux pinces peut être le total de la tension à vide des deux machines.
 - f. Si on utilise la machine à souder comme une source de courant pour soudage semi-automatique, ces précautions pour le porte-électrode s'appliquent aussi au pistolet de soudage.
2. Dans le cas de travail au dessus du niveau du sol, se protéger contre les chutes dans le cas où on reçoit un choc. Ne jamais enrouler le câble-électrode autour de n'importe quelle partie du corps.
3. Un coup d'arc peut être plus sévère qu'un coup de soleil, donc:
 - a. Utiliser un bon masque avec un verre filtrant approprié ainsi qu'un verre blanc afin de se protéger les yeux du rayonnement de l'arc et des projections quand on soude ou quand on regarde l'arc.
 - b. Porter des vêtements convenables afin de protéger la peau de soudeur et des aides contre le rayonnement de l'arc.
 - c. Protéger l'autre personnel travaillant à proximité au soudage à l'aide d'écrans appropriés et non-inflammables.
4. Des gouttes de laitier en fusion sont émises de l'arc de soudage. Se protéger avec des vêtements de protection libres de l'huile, tels que les gants en cuir, chemise épaisse, pantalons sans revers, et chaussures montantes.
5. Toujours porter des lunettes de sécurité dans la zone de soudage. Utiliser des lunettes avec écrans latéraux dans les zones où l'on pique le laitier.
6. Eloigner les matériaux inflammables ou les recouvrir afin de prévenir tout risque d'incendie dû aux étincelles.
7. Quand on ne soude pas, poser la pince à un endroit isolé de la masse. Un court-circuit accidentel peut provoquer un échauffement et un risque d'incendie.
8. S'assurer que la masse est connectée le plus près possible de la zone de travail qu'il est pratique de le faire. Si on place la masse sur la charpente de la construction ou d'autres endroits éloignés de la zone de travail, on augmente le risque de voir passer le courant de soudage par les chaînes de levage, câbles de grue, ou autres circuits. Cela peut provoquer des risques d'incendie ou d'échauffement des chaînes et des câbles jusqu'à ce qu'ils se rompent.
9. Assurer une ventilation suffisante dans la zone de soudage. Ceci est particulièrement important pour le soudage de tôles galvanisées plombées, ou cadmiées ou tout autre métal qui produit des fumées toxiques.
10. Ne pas souder en présence de vapeurs de chlore provenant d'opérations de dégraissage, nettoyage ou pistologie. La chaleur ou les rayons de l'arc peuvent réagir avec les vapeurs du solvant pour produire du phosgène (gas fortement toxique) ou autres produits irritants.
11. Pour obtenir de plus amples renseignements sur la sûreté, voir le code "Code for safety in welding and cutting" CSA Standard W 117.2-1974.

PRÉCAUTIONS DE SÛRETÉ POUR LES MACHINES À SOUDER À TRANSFORMATEUR ET À REDRESSEUR

1. Relier à la terre le châssis du poste conformément au code de l'électricité et aux recommandations du fabricant. Le dispositif de montage ou la pièce à souder doit être branché à une bonne mise à la terre.
2. Autant que possible, l'installation et l'entretien du poste seront effectués par un électricien qualifié.
3. Avant de faire des travaux à l'intérieur de poste, la débrancher à l'interrupteur à la boîte de fusibles.
4. Garder tous les couvercles et dispositifs de sûreté à leur place.

Thank You—

for selecting a **QUALITY** product by Lincoln Electric. We want you to take pride in operating this Lincoln Electric Company product ... as much pride as we have in bringing this product to you!

Please Examine Carton and Equipment For Damage Immediately

When this equipment is shipped, title passes to the purchaser upon receipt by the carrier. Consequently, Claims for material damaged in shipment must be made by the purchaser against the transportation company at the time the shipment is received.

Please record your equipment identification information below for future reference. This information can be found on your machine nameplate.

Model Name & Number _____

Code & Serial Number _____

Date of Purchase _____

Whenever you request replacement parts for or information on this equipment always supply the information you have recorded above.

Read this Operators Manual completely before attempting to use this equipment. Save this manual and keep it handy for quick reference. Pay particular attention to the safety instructions we have provided for your protection. The level of seriousness to be applied to each is explained below:

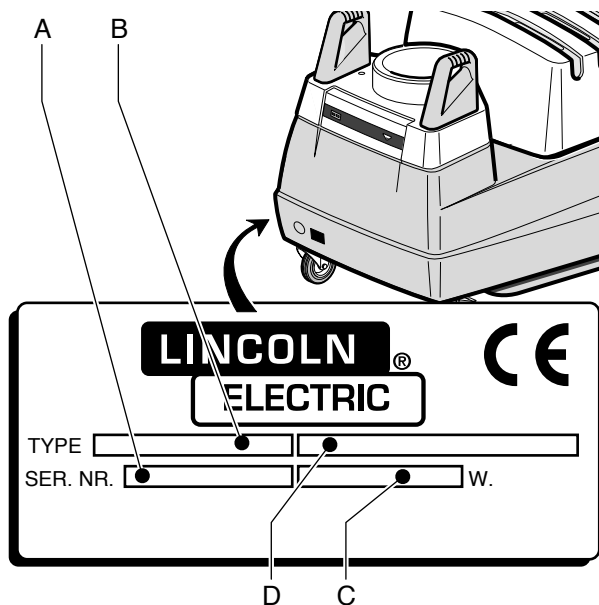

The identification plate specifies:

- A. Serial number
- B. Product name
- C. Power consumption
- D. Supply voltage and frequency

⚠ WARNING

This statement appears where the information **must** be followed **exactly** to avoid **serious personal injury** or **loss of life**.

⚠ CAUTION

This statement appears where the information **must** be followed to avoid **minor personal injury** or **damage to this equipment**.

TABLE OF CONTENTS

	Page
Safety	i-iv
<hr/>	
Installation	Section A
Technical Specifications	A-1
Safety Precautions	A-2
General Description.....	A-2
Mounting the Extraction Arm	A-3
Electrical Installation.....	A-4
Installing the Lamp Options and Automatic start/stop arc sensor	A-4
<hr/>	
Operation	Section B
Safety Instructions	B-1
Operating Instructions	B-1
<hr/>	
Maintenance	Section C
Routine Maintenance	C-1
Replacing the filter	C-1
<hr/>	
Trouble Shooting	Section D
Trouble Shooting Chart	D-1
<hr/>	
Wiring Diagram	Section E
Wiring Diagram for K1653-1 Mobiflex 200-M	E-1
Wiring Diagram for K1653-2 Mobiflex 200-M with Transformer	E-2
Wiring Diagram for Mobiflex 200-M with Lamp Option and Arc Sensor	E-3
<hr/>	
Parts List	P319 Series
<hr/>	

Technical Specifications- Mobiflex 200-M

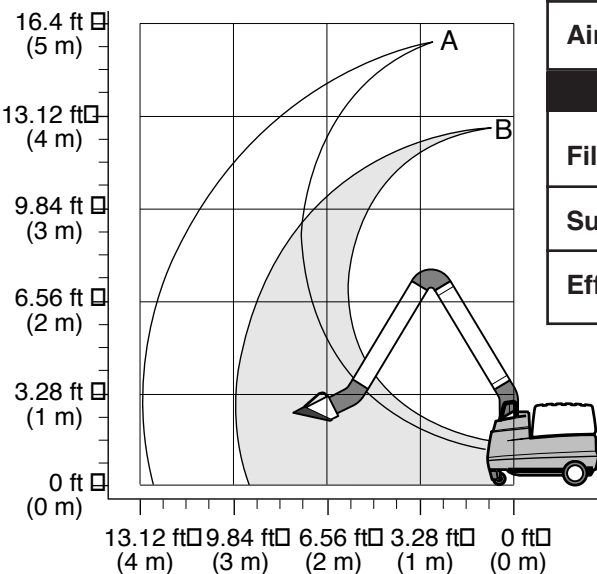
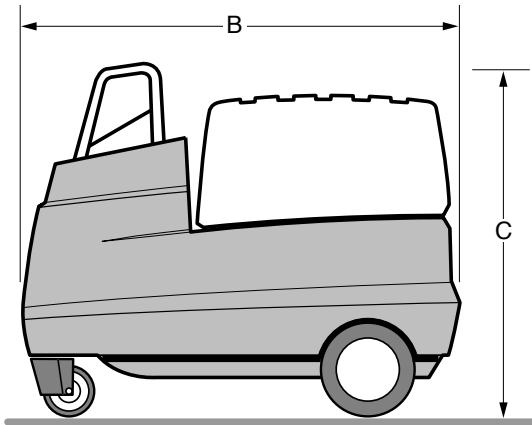
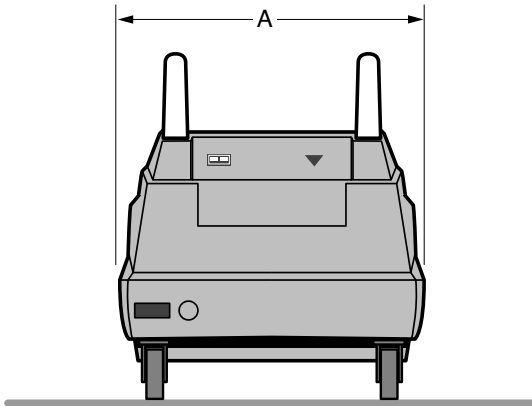

GENERAL	
Sales Spec.	K1653-1 Mobiflex 200-M K1653-2 Mobiflex 200-M with Transformer
Input Voltage	115V, 1 Ph, 60 Hz
Rated Current Draw	10.0 A
Power Rating	0.75 kW
Sound Level	69 dB(A)
Weight	Approx. 200 lbs. (91 kg)
OVERALL DIMENSIONS	
A Overall Width	31.9 in. (810 mm)
B Overall Length	47.7 in. (1210 mm)
C Overall Height	35.5 in. (900 mm)
AMBIENT CONDITIONS	
Min. Temperature	41°F (5°C)
Max. Temperature	113°F (45°C)
Max. Rel. Humidity	80%
AIRFLOW	
Extraction Type	Low Vacuum, High Volume
Airflow Rate	735 CFM (1,250 m ³ /h)
FILTER	
Filter Type	Pretreated Paper Cartridge
Surface Area	539 ft ² (50m ²)
Efficiency	99.8% (stabilized)

NOTE: Technical Specifications are subject to change without prior notice. Specifications and guarantees are valid only when specified spare parts and filters are used.

MOBIFLEX 200-M



Read this entire installation section before you start installation.

SAFETY PRECAUTIONS

Do not attempt to use this equipment until you have thoroughly read all installation, operating and maintenance information supplied with your equipment. They include important safety precautions and detailed operating and maintenance instructions.

WARNING



ELECTRIC SHOCK can kill.

- Do not touch electrically live parts such as internal wiring.
- Turn the input power off at the fuse box before working on this equipment.
- Have a qualified person install and service this equipment.



MOVING PARTS can injure.

- Do not operate without extraction arm installed.
- Keep away from moving parts.

Only qualified personnel should install, use or service this equipment.

GENERAL DESCRIPTION

The Mobiflex 200-M is a self-contained system for the removal and filtration of welding fume particles and other particulate. It is a low vacuum, high volume system that uses a spring balanced, articulated arm to provide localized ventilation for welding or other applications. With large rear wheels and front casters, it is suitable for use in relatively small workshops or on mobile fume sources. A wheel locking mechanism provides stability while positioning the arm. The Mobiflex 200-M is suitable for light duty, intermittent use. It has an 18 ft. (6 m) input cord with a standard 115VAC, 1ph, 60Hz plug. The filter system features a spark arrester and a square, disposable paper filter cartridge with a filtering efficiency of 99.8%. Fume is captured on the inside of the cartridge, keeping hands clean during filter maintenance.

The Mobiflex 200-M can be used with either a 10 ft. or 13 ft. extraction arm. The hood of the arm can be retrofitted with a 24VAC lamp kit with remote, hood-mounted switch for the blower. An automatic start/stop arc sensor is also available for use with the lamp kit.

This device automatically switches the Mobiflex unit on when it senses a welding arc, and off when it does not sense the arc.

This manual covers installation of a K1653-1 or K1653-2 Mobiflex 200-M

with a K1655-1 LFA 3.1, 10 ft. Arm
or a K1655-2 LFA 4.1, 13 ft. Arm

This manual also covers installation of the appropriate optional Lamp Kit:

On a K1653-1 Mobiflex 200-M: a K1669-1 Lamp Kit or K1669-3 Lamp Kit with Arc Sensor
On a K1653-2 Mobiflex 200-M: a K1706-1 Work Lamp or K1706-2 Work Lamp with Arc Sensor.

Instructions are also included to install the optional K1670-1 Arc Sensor in either the K1669-1 Lamp Kit or K1706-1 Work Lamp.

Note: The K1706-1 and K1706-2 Work Lamp options cannot be combined with a K1653-1 Mobiflex 200-M.

This installation section covers the following machines:

K1653-1 Mobiflex 200-M
K1653-2 Mobiflex 200-M with Transformer Relay Kit
This installation section covers any of the following accessories as installed on the above machines:

K1655-1 LFA 3.1, 10 ft. Arm
K1655-2 LFA 4.1, 13 ft. Arm
K1669-1 Lamp Kit for K1653-1 Mobiflex 200-M
K1669-3 Lamp Kit with Arc Sensor for K1653-1
K1706-1 Work Lamp for K1653-2 Mobiflex 200-M
K1706-2 Work Lamp with Arc Sensor for K1653-2
K1670-1 Arc Sensor



The K1653-1 Mobiflex 200-M includes:

- Mobile base unit
- Flexible hose for connecting the extraction arm

The K1653-2 Mobiflex 200-M includes:

- Mobile base unit
- Flexible hose for connecting the extraction arm
- Factory-installed Transformer Relay Kit

The LFA 3.1 or 4.1 extraction arm includes:

- Assembled arm, 2 sections
- Flexible hose, (2) 8" Rubber seals for hood hinge
- Hood assembly
- (2) Bolts, M8x1.25, 45mm long (about 1.75")
- (2) Nuts, M8 self-locking
- Hose running guard 
- Clamping pin for red plastic ring 
- Metal rotating hinge
- Red plastic ring

MOBIFLEX 200-M



⚠ WARNING

Only qualified personnel should install, use or service this equipment.

⚠ CAUTION

Leave the tape and plastic packaging on the extraction arm sections until the arm is completely installed (including mounting the hood). The arm is spring-balanced to compensate for the weight of the hood and will spring out quickly if it is not mounted securely, with the hood in place.

The Mobiflex 200-M base unit is packed with the right-front (when facing the inlet) wheel locked. To unlock the wheel: using a sturdy screwdriver, push down (hard) on the tab over the wheel, until it clicks and the gold tab (underneath) pops up.

MOUNTING THE EXTRACTION ARM

After unpacking the base unit, stabilize it while mounting the arm by re-locking the front wheel. To lock the wheel, with your shoe or a sturdy screwdriver, push on the gold tab (on the right front wheel) until it snaps down.

The rotating hinge of the arm comes in three pieces: Metal rotating hinge, red plastic ring, and clamping pin. Refer to Figure 1.

1. Slip the clamping pin through the hole in the rotating rod.
2. Fit the red plastic ring over the clamping pin.
3. Rotate the clamping pin to snap it into place on the U-shaped indents on the red plastic ring.

The lip of the ring should fit securely against the top edge of the rotating flange, yet rotate with the rod.

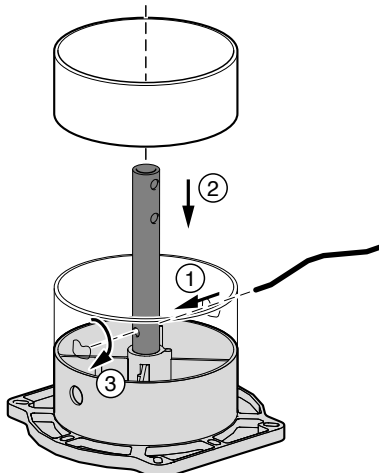
**Fig. 1**

Remove the red plastic cover from over the handles by removing the four Phillips-head screws. Mount the rotating hinge assembly over the inlet (Fig. 2, Item C) so the cable hole (Fig. 2, Item B) is in the front. Use the eight (1.25") bolts supplied with the Mobiflex to secure the rotating hinge assembly.

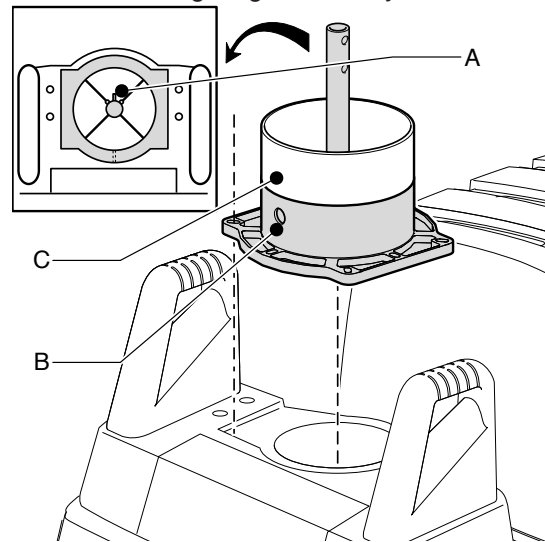
**Fig. 2**

Place one rubber seal (Fig. 3, Item B) fully onto the red plastic ring. Roll the top half of the rubber seal down onto itself and slide the connection hose (Fig. 3, Item A) over the red plastic ring (Fig. 3, Item C). Roll the rubber seal up over the end of the connection hose. If installing a lamp kit, leave the red cover loose for further installation procedures. If not, replace the cover over the large handles and secure with the four phillips-head screws.

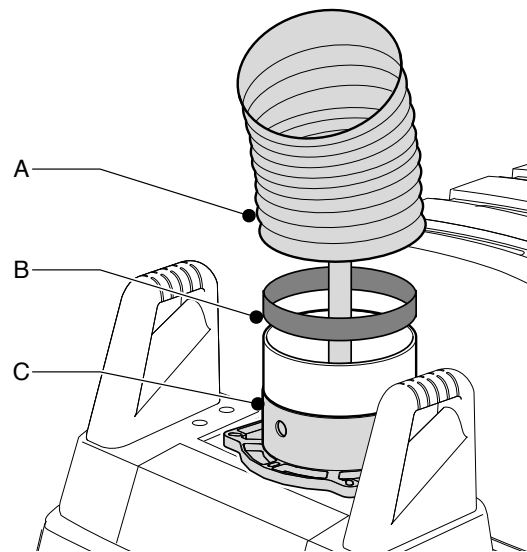
**Fig. 3**

MOUNTING THE EXTRACTION ARM

(continued)

Place the other rubber seal around base of the arm tube. **MOUNT THE ARM IN THE VERTICAL POSITION!** Rotate the hinge rod so the stop pin is in the back, and mount the arm (Fig. 4, Item A) on the hinge rod (Fig. 4, Item B); use the two (1 3/4") bolts and nuts in the two connecting holes as shown in the inset of Fig. 4.

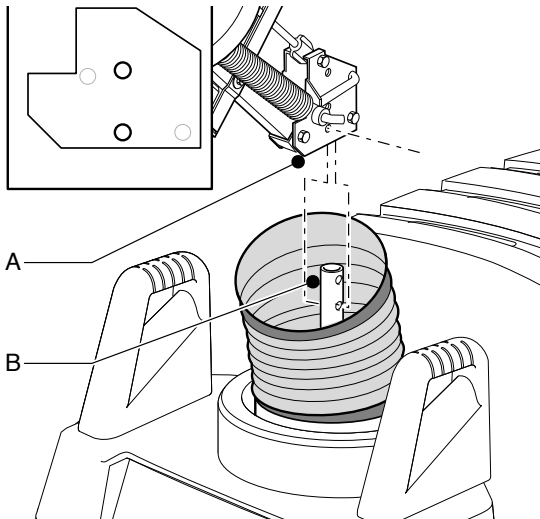

Fig. 4

⚠ CAUTION

Leave the tape and plastic packaging on the extraction arm sections until the arm is completely installed (including mounting the hood). The arm is spring-balanced to compensate for the weight of the hood and will spring out quickly if it is not mounted securely, with the hood in place.

Position one 8" rubber seal (Fig. 5, Item B) and the flexible hose supplied with the arm (Fig. 5, Item C) onto the hood end of the arm (Fig. 5, Item A).

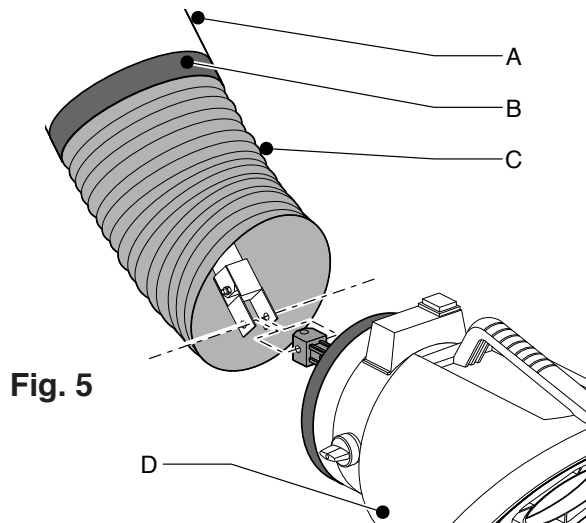

Fig. 5

Put the last rubber seal on the hood connection. Mount the hood to the arm.

Remove the plastic and tape from the arm sections.

Snap the "hose running guard" onto the middle hinge section so the "nose" end faces the base of the arm as shown in Figure 6.

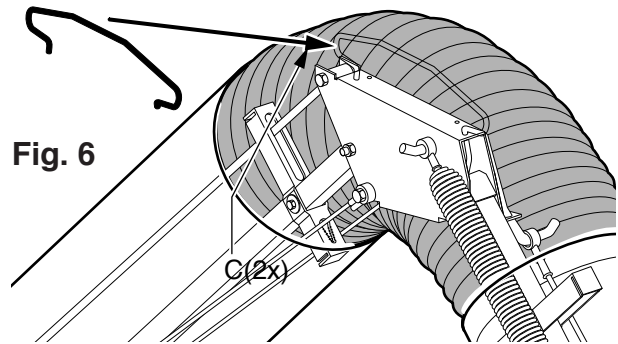

Fig. 6

ADJUSTING THE BALANCE AND MOVEMENT OF THE ARM

⚠ WARNING

Do not attempt to change the spring tension. Springs are factory set and once released, cannot be reset in the field. Balance and movement adjustments are only made through adjustments of the friction connections.

When installing the arm, adjust the friction connections to convenient settings. These connections are located at the base hinge, at the front and back of the middle hinge, and in two directions at the hood hinge. Reference the maintenance section of the instruction manual for the LFA Extraction Arm for details. After adjusting the friction connections and installing any lamp options that you have purchased, seal all connecting hoses with the rubber seals as described earlier.

INSTALLING THE LAMP OPTIONS AND ARC SENSOR

Each of the lamp option packages provides convenient hood-mounted switches for both the light and Mobiflex 200-M.

Either the optional K1669-1 Lamp Kit or K1706-1 Work Lamp package can be combined with a K1670-1 Automatic start/stop arc sensor to automatically switch the Mobiflex unit on and off when the sensor detects an arc. The K1669-3 Lamp Kit and K1706-2 Work Lamp come with the Arc Sensor pre-installed in the lamp housing.

MOBIFLEX 200-M

LINCOLN
ELECTRIC

INSTALLING THE LAMP OPTIONS AND ARC SENSOR

The K1669-1 Lamp Kit Includes:

Work Lamp
13 ft., 3-Wire, 20 Ga. Connection Cable
Transformer Relay Kit

The K1669-3 Lamp Kit with Arc Sensor Includes:

Work Lamp
13 ft., 3-Wire, 20 Ga. Connection Cable
Transformer Relay Kit
Factory-installed Automatic Start/Stop Arc Sensor

The K1706-1 Work Lamp Includes:

Work Lamp
13 ft., 3-Wire, 20 Ga. Connection Cable

The K1706-2 Work Lamp with Arc Sensor Includes:

Work Lamp
13 ft., 3-Wire, 20 Ga. Connection Cable
Factory-installed Automatic Start/Stop Arc Sensor

GENERAL PREPARATION

1. Pop out the sealing plate (Fig. 7, Item A) on the top of the hood with a screwdriver.
2. Remove the six screws (Fig. 7, Item C) and the air-flow focus vanes (Fig. 7, Item B).
3. Open the airflow throttle valve (Fig. 7, Item D).

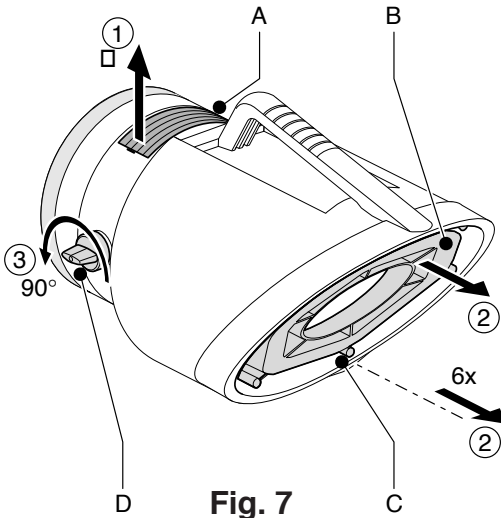

Fig. 7

MOUNTING THE ARC SENSOR IN THE LAMP HOUSING

If not installing the K1670-1 Auto start/stop arc sensor, skip to the next step, "Mounting the lamp housing in the hood". The K1669-3 Lamp Kit and K1706-2 Work Lamp have the Arc Sensor built into the lamp housing.

Note: If the lamp housing assembly has (5) leads, the Arc Sensor is already installed. Skip to the next step "Mounting the lamp housing in the hood."

Use a small phillips-head screwdriver to remove the six screws that hold the lamp housing (Fig. 8, Item A) together. Insert the sensor housing (Fig 8, Item B) with the sensor 'eye' away from the lamp. Route all 5 leads through the lamp housing "leg" and out the opening as shown in Figure 8. Replace the other half of the lamp housing, and tighten the screws.

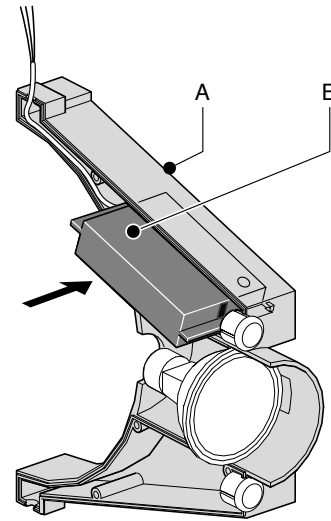

Fig. 8

MOUNTING THE LAMP HOUSING IN THE HOOD

Feed the lamp (and sensor leads, if used) through the hole (Fig. 9, Item A) in the top of the hood; push the top leg of the lamp housing into position, then snap in the bottom leg. Remount the airflow focus vanes in the open end of the hood, using the six screws (Fig. 7, Item C).

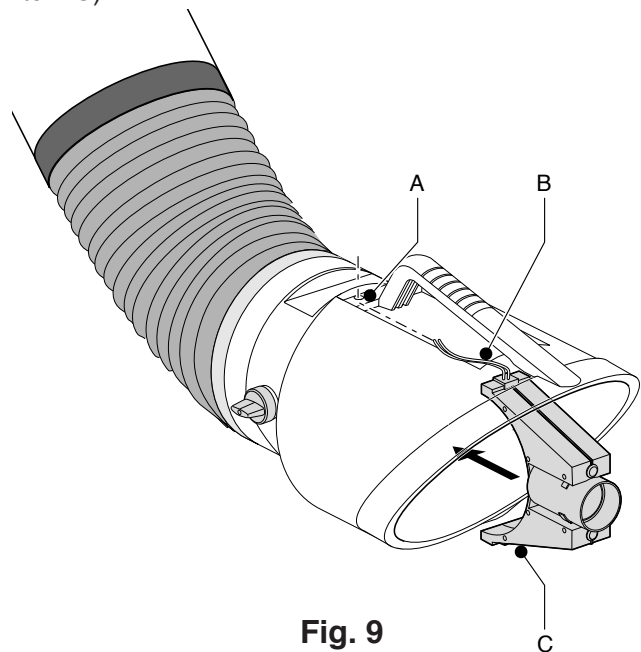

Fig. 9

INSTALLING THE LAMP OPTIONS AND ARC SENSOR

(continued)

MAKING THE CONNECTIONS AT THE HOOD

Feed the 13 ft. connecting cable through the hole in the hood (Fig. 10, Item B).

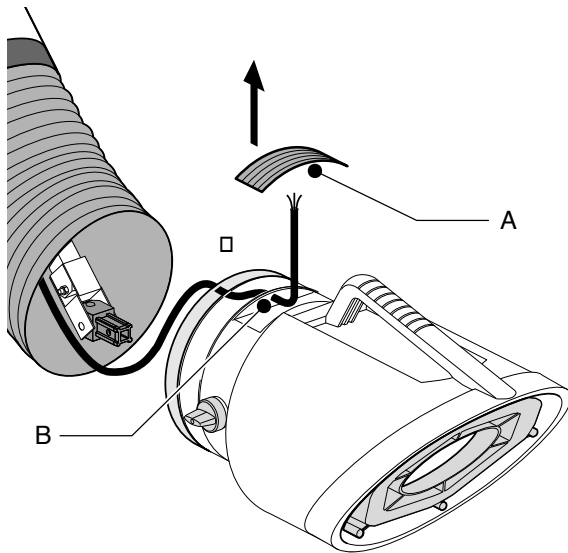
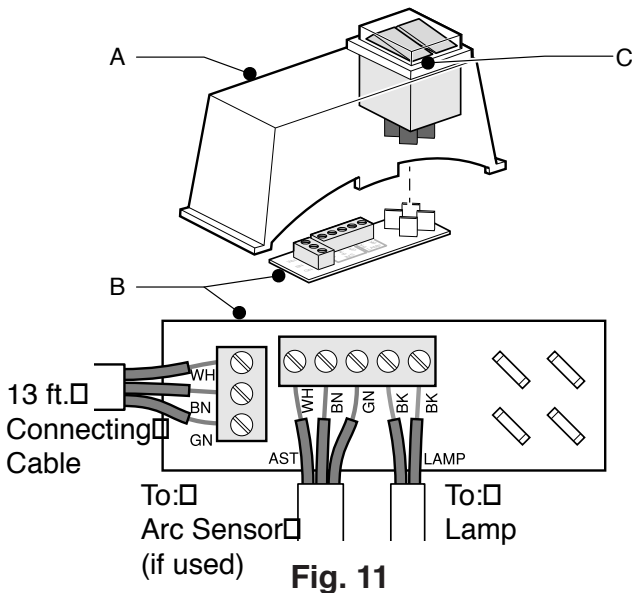

Fig. 10

Have a qualified electrician connect the 13 ft. connecting cable leads, lamp leads, and sensor leads (if used) to the control board (Fig. 11, Item B). Push the board onto the bottom of the remote switch (Fig. 11, Item C). Snap the switch box into place atop the hood.



ELECTRICAL INSTALLATION

Connect the Mobiflex 200-M to 115VAC single phase, grounded receptacle suitable for 15 amp service.

INSTALLING THE OPTIONAL LAMP KIT AND AUTOMATIC START/STOP ARC SENSOR

(continued)

Route the 13 ft. connecting cable through the four cable holders in the arm (Fig. 12, Points D). Leave plenty of slack at each hinge to allow for the full range of movement of the arm. Secure the cable in the cable holders (Fig. 12, Inset). Exit the arm through the cable hole in the rotating hinge; use a knife to cut a small X-pattern in the grommet and push the cable through.

Use the supplied wire ties to secure the cable as shown in Fig. 13.

Seal all hose joint connections with the rubber seals.

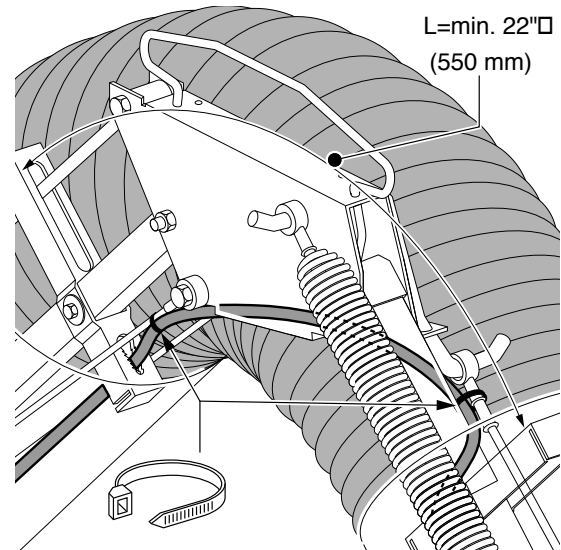

Fig. 13

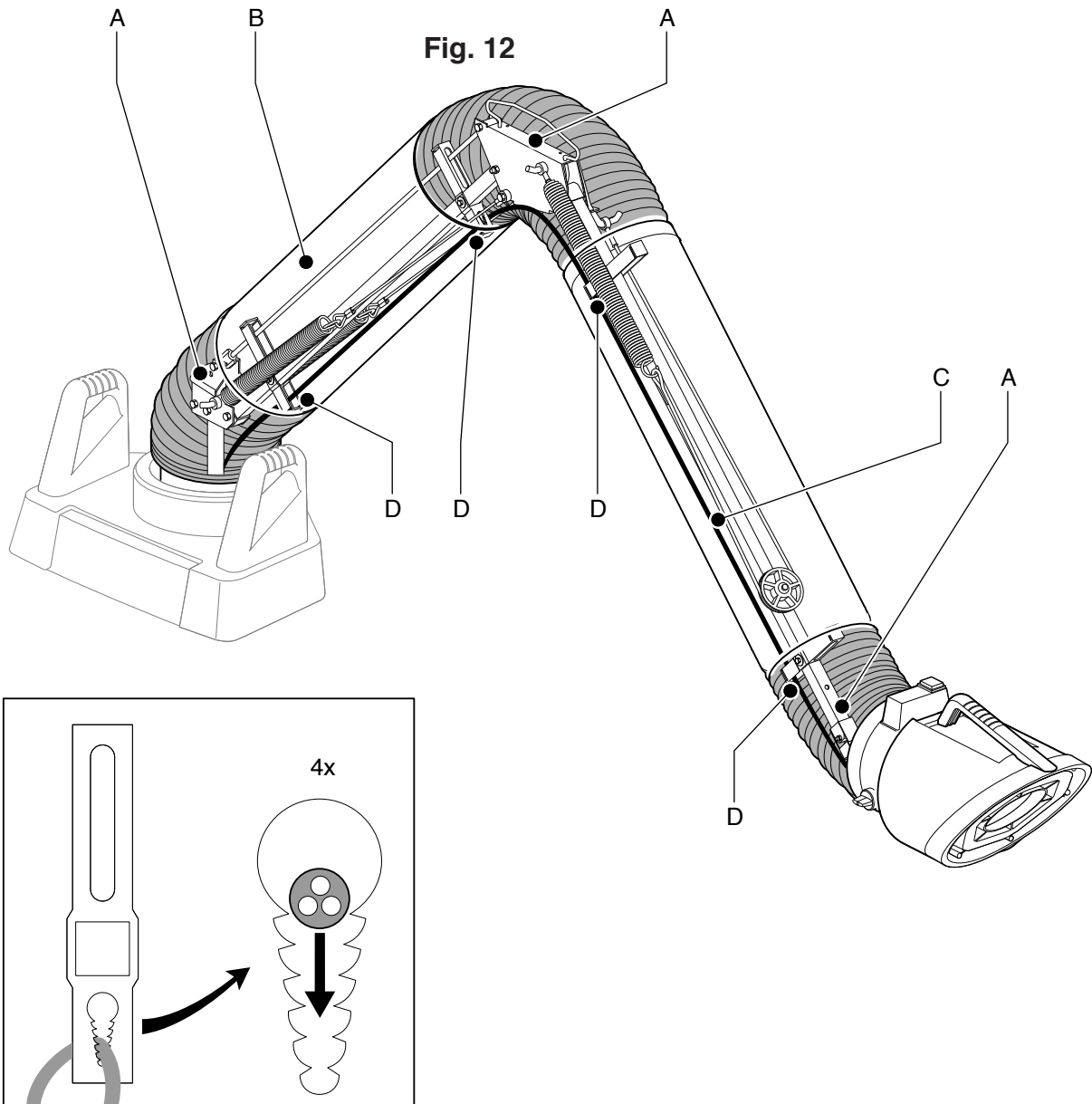

Fig. 12

MOBIFLEX 200-M

LINCOLN
ELECTRIC

INSTALLING THE LAMP OPTIONS AND ARC SENSOR

(continued)

Loosen the four screws of the cover, lift the cover around the arm and turn it 180 degrees, and allow it to rest on the filter cover. Remove the control cover (Fig. 14, Item A), secured by four screws as shown. Route the 13 ft. connecting cable through the grommet in the control cover (cut an X as before).

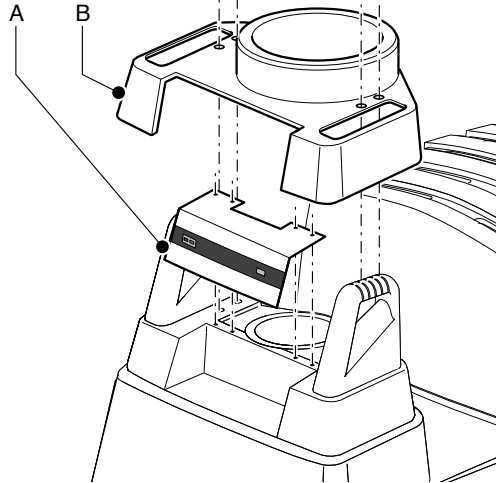

Fig. 14

⚠ WARNING

ELECTRIC SHOCK can kill.



- Do not touch electrically live parts such as internal wiring.
- Turn the input power off at the fuse box before working on this equipment.
- Have a qualified person install and service this equipment.

MOUNTING THE TRANSFORMER RELAY KIT (K1653-1 Mobiflex 200-M only)

When installing a K1653-1 Mobiflex 200-M with a K1669-1 or K1669-3 Lamp Kit:

Note: If the control panel has the Contactor, Transformer, Fuseblock/Fuse, and Terminal Block already installed (as in Fig. 15), skip to the next step “Making the connections at the Control Panel.”

Use the seven supplied screws to mount the pieces of the Transformer Relay Kit in the Control Panel of the Mobiflex unit as shown in Figure 15. Use the two smaller screws to mount the terminal block (E), one of the larger screws to mount the fuse holder (C), and the four remaining large screws to mount the transformer (B).

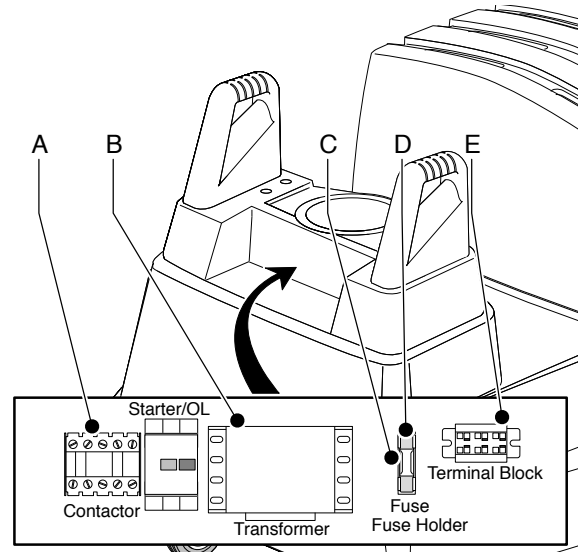

Fig. 15

Mount the Contactor (A) on the DIN rail next to the Starter/Overload. The mounting points have been marked on the mounting surface of the control panel.

Have a qualified electrician make the connections according to the wiring diagram in the back of this manual. Reference wiring diagrams for “K1653-1 Mobiflex 200-M” and “Mobiflex 200-M with Lamp Option and Arc Sensor” in the back of this manual.

Note: The (2) fan motor wires must be moved from the top of the Starter/OL to the bottom of the Contactor. Reference the wiring diagram in the back of this manual for details.

Loop any extra cable inside the control box. Replace the control cover and large cover over the handles.

MAKING CONNECTIONS AT THE CONTROL PANEL (K1653-2 Mobiflex 200-M with Transformer only)

When installing a K1653-2 Mobiflex 200-M with a K1706-series Work Lamp:

Note: To insert conductors in Terminal Block, push in on front opening with small screwdriver, and insert conductor into corresponding top opening.

Note: GN is not the same potential as Ground.

Remove the jumper on the terminal block. Connect the leads of the 13 ft. connecting cable according to color (WH, BN, GN). Loop any extra cable inside the control box. Replace the control cover and large cover over the handles.

Read and understand this entire section before operating your Mobiflex 200-M.

SAFETY INSTRUCTIONS

Do not attempt to use this equipment until you have thoroughly read all operating and maintenance manuals supplied with your equipment and any related welding machine it will be used with. They include important safety precautions, operating and maintenance instructions and parts lists.

WARNING



ELECTRIC SHOCK can kill.

- Do not touch electrically live parts such as output terminals or internal wiring.
- Insulate yourself from the work and ground.
- Always wear dry insulating gloves.



WELDING SPARKS can cause fire or explosion.

- Keep flammable material away.
- Do not weld upon containers which have held combustibles.



ARC RAYS can burn.

- Wear eye, ear and body protection.



FUMES AND GASES can be dangerous.

- Although the removal of the particulate matter from welding smoke may reduce the ventilation requirement, concentrations of the clear exhausted fumes and gases may still be hazardous to health. Avoid breathing concentrations of these fumes and gases. Use adequate ventilation when welding. See ANSI Z49.1, "Safety in Welding and Cutting", published by the American Welding Society.

Only qualified personnel should operate this equipment.

ADDITIONAL SAFETY PRECAUTIONS

Always operate this equipment with the filter and arm installed and all covers in place as these provide maximum protection from moving parts and insure proper vacuum operation and cooling air flow.

OPERATING INSTRUCTIONS

Connect to 120 VAC input power and turn on.

Position hood within 10-15 inches (250-400mm) of the arc. **DO NOT USE FOR CUTTING OR GOUGING OPERATIONS.** The Mobiflex 200-M is recommended for light duty or intermittent use. Although it can be used in production applications, this may require very frequent maintenance or replacement of the filter cartridge. Use of the Mobiflex 200-M disposable filter system is cost effective if consumable use at the station is less than 1500 lbs. per year of solid wire or 1100 lbs. per year of flux-shielded consumables.

FILTER MAINTENANCE INDICATOR

With use, the filter will fill up with collected fume. With the Mobiflex 200-M turned on and the fan running, check the maintenance indicator on the front panel of the machine. The indicator will move gradually from white to red as the filter becomes saturated, letting you know ahead of time how close the filter is to clogging.

When the maintenance indicator shows that the filter is clogged (full red), replace the filter.

ROUTINE MAINTENANCE

Every 3 months, clean the inside of the machine with a vacuum cleaner, including the filter compartment and spark arrester. Check the filter for damage or saturation.

Every 12 months, have a qualified technician check the blower fan and housing for encrusted particles and clean if necessary. Check the sealing material of the extraction fan and replace if necessary.

REPLACING THE FILTER CARTRIDGE

Replace the filter when it has been damaged, when the indicator shows that the filter is clogged, or when airflow is reduced to the point that extraction performance is no longer satisfactory (extracts welding fume with the hood positioned within 10-15 inches of the welding arc).

⚠ WARNING

The particulate matter collected may be dangerous to your health. Take necessary precautions so that you and your fellow workers do not breathe the dust and particulate. Wear a suitable respirator when disposing of the particulate.

Check with local authorities for regulations governing the disposal of this material.

1. Disconnect the machine from input power.
2. Unscrew the thumb nut (Fig. 16, Item A) and remove the filter cover (Fig. 16, Item B).
3. Unscrew the nut (Fig. 17, Item A) and remove the filter sealing plate (Fig. 17, Item B).
4. Lift the filter cartridge (Fig. 18, Item A) up and out of the machine. It is not necessary to remove the spark arrester (Fig. 18, Item B). Clean the spark arrester and filter compartment with a vacuum cleaner.
5. Install the new filter and replace the filter sealing-plate, nut, filter cover, and thumb nut.

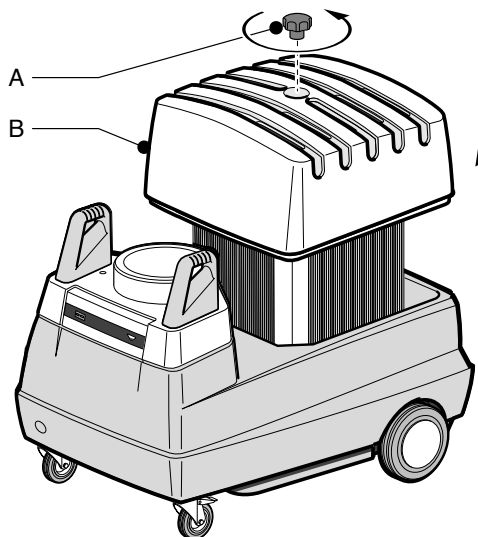

Fig. 16

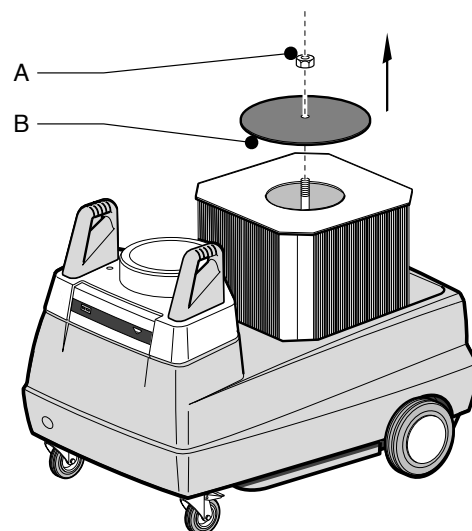

Fig. 17

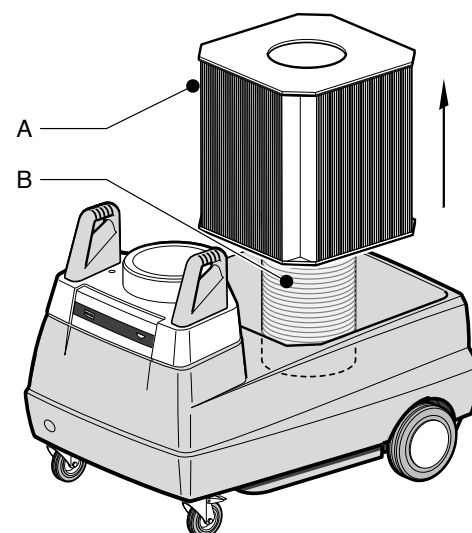

Fig. 18

Observe all Safety Guidelines detailed throughout this manual

SYMPTOM	PROBLEM	SOLUTION
Motor does not start.	<p>No input power.</p> <p>Input cord damaged.</p> <p>Loose contacts.</p> <p>Starter/overload switch damaged or defective.</p> <p>Motor damaged or defective.</p>	<p>Verify 115VAC/60Hz, 1ph input power.</p> <p>Check the integrity of the input cord.</p> <p>Check the contacts.</p> <p>Repair or replace the starter/overload switch in the control panel.</p> <p>Repair or replace the motor.</p>
Motor hums, but no suction.	Motor capacitor defective or not connected.	Reconnect or replace the motor capacitor.
Motor stops automatically.	<p>Motor overload protection activated.</p> <p>Motor defective or damaged.</p>	<p>Let the machine cool down for a few minutes. Adjust Starter/Overload to 10A.</p> <p>Repair or replace the motor.</p>
Poor suction.	<p>Leakage.</p> <p>Outlet grid blocked.</p> <p>Air path in arm blocked.</p> <p>Filter blocked (check Maintenance Indicator).</p> <p>Spark arrester blocked.</p> <p>Blower fan blocked.</p> <p>Fan seal damaged.</p>	<p>Check hose connections and integrity</p> <p>Remove obstructions from outlet grid.</p> <p>Remove obstructions from arm.</p> <p>Replace filter if necessary.</p> <p>Clean the spark arrester.</p> <p>Clean excess fume or spatter from fan.</p> <p>Check or replace sealing material of fan.</p>
Dust or smoke coming out of outlet grid.	Filter damaged, or not seated correctly.	Replace the filter or reseal it.
Vibrations in the machine.	Imbalance in the fan.	Clean excess dirt from fan.

 **CAUTION**

If for any reason you do not understand the test procedures or are unable to perform the tests/repairs safely, contact your **Local Lincoln Authorized Field Service Facility** for technical troubleshooting assistance before you proceed.

MOBIFLEX 200-M



WIRING DIAGRAM FOR K1653-1 MOBIFLEX 200-M

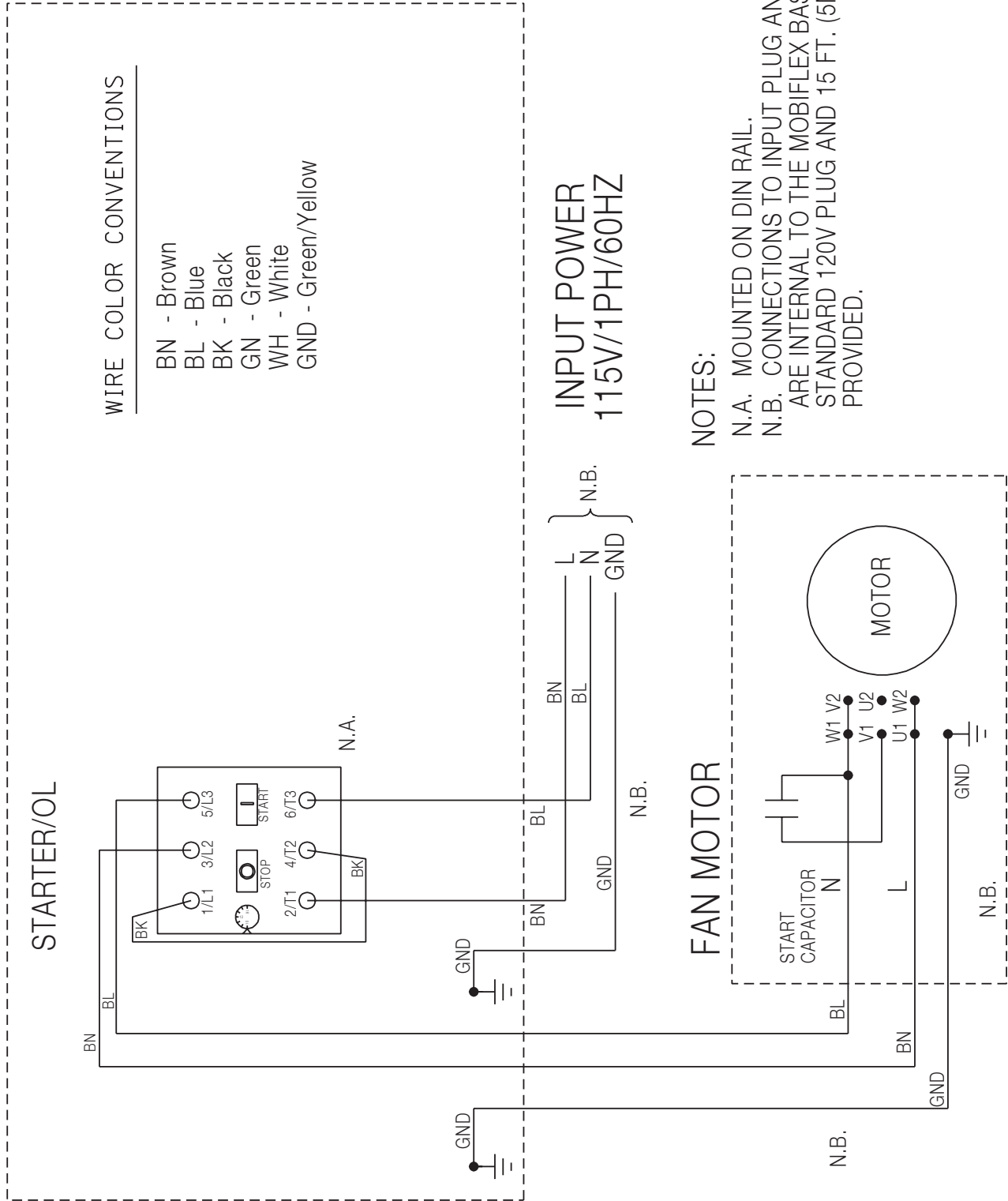

S23315

WIRING DIAGRAM FOR K1653-2 MOBIFLEX 200-M WITH TRANSFORMER

CONTROL PANEL - MOBIFLEX BASE UNIT

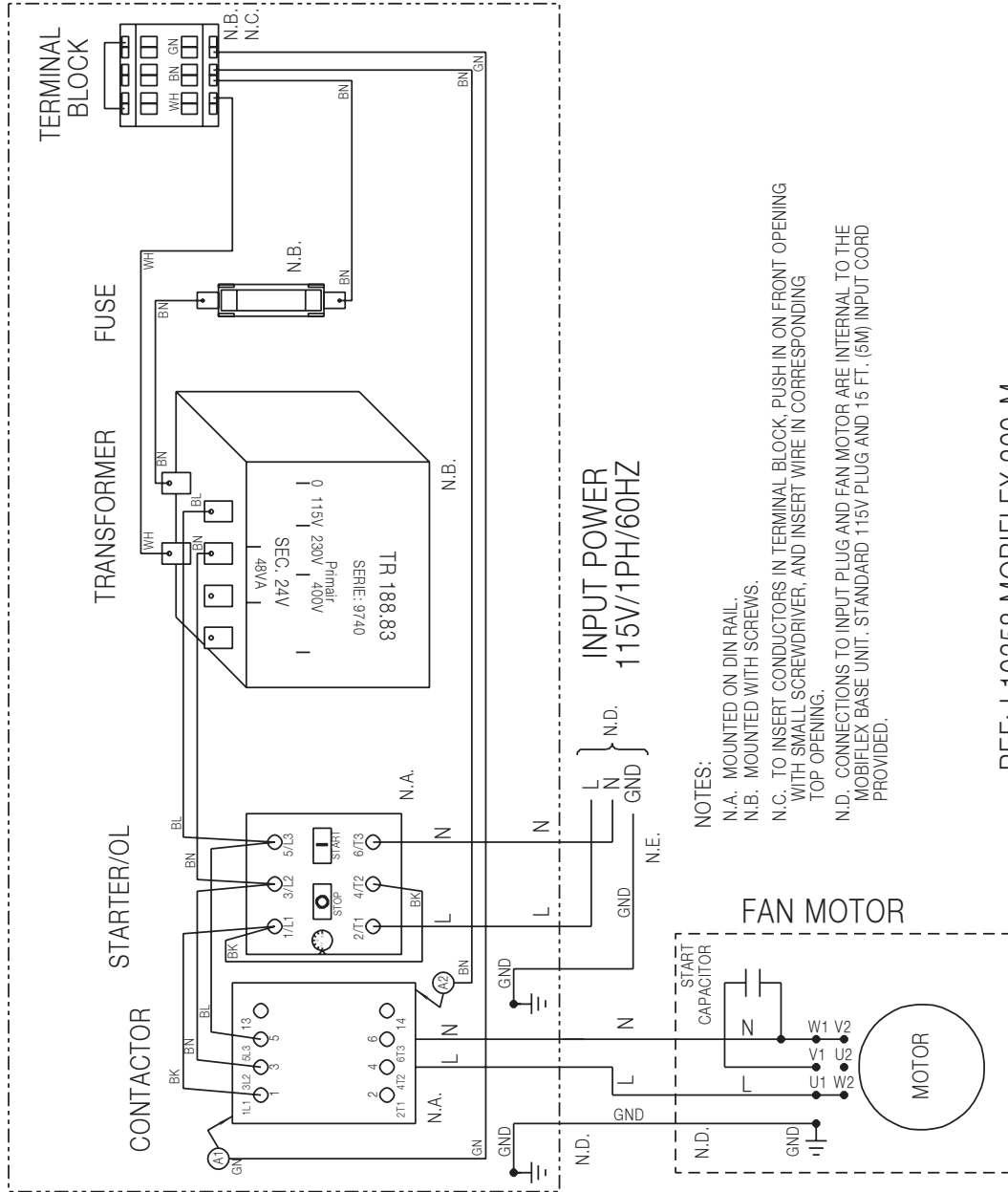

WIRE COLOR CONVENTIONS

- L - Black
- N - White
- BN - Brown
- BL - Blue
- BK - Black
- GN - Green
- WH - White
- GND - Green or Green/Yellow

INPUT POWER
115V/1PH/60HZ

NOTES:

- N.A. MOUNTED ON DIN RAIL.
- N.B. MOUNTED WITH SCREWS.
- N.C. TO INSERT CONDUCTORS IN TERMINAL BLOCK, PUSH IN ON FRONT OPENING WITH SMALL SCREWDRIVER, AND INSERT WIRE IN CORRESPONDING TOP OPENING.
- N.D. CONNECTIONS TO INPUT PLUG AND FAN MOTOR ARE INTERNAL TO THE MOBIFLEX BASE UNIT. STANDARD 115V PLUG AND 15 FT. (5M) INPUT CORD PROVIDED.

C
S 23315-4

REF: L10358 MOBIFLEX 200-M

WIRING DIAGRAM FOR MOBIFLEX 200-M WITH LAMP OPTION AND ARC SENSOR

WORK LAMP

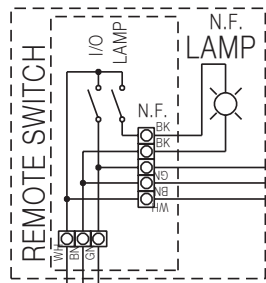

AUTO START/STOP ARC SENSOR

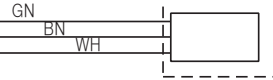

13 FT. CONNECTION CABLE

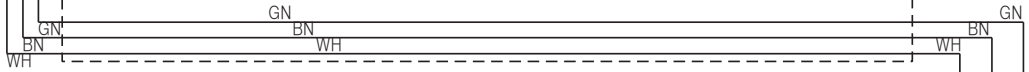

CONTROL PANEL - MOBIFLEX BASE UNIT

WIRE COLOR CONVENTIONS

- BN - Brown
- BL - Blue
- BK - Black
- GN - Green
- WH - White
- GND - Green/Yellow

CONTACTOR

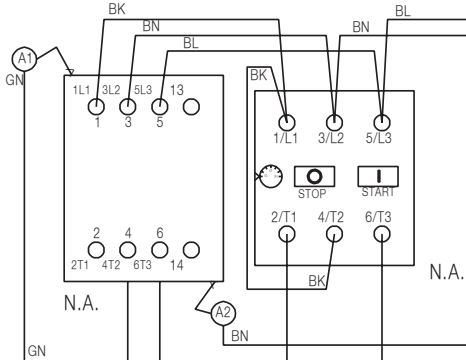

STARTER/OL

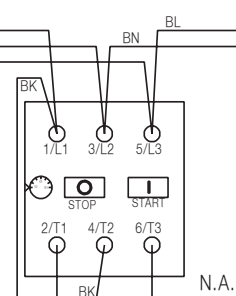

TRANSFORMER

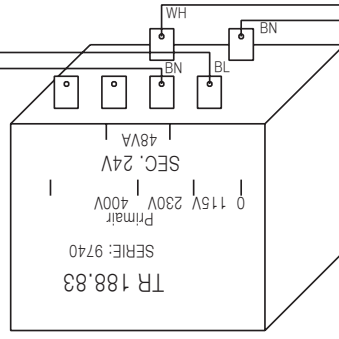

FUSE

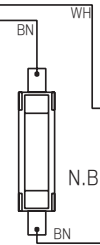

TERMINAL BLOCK

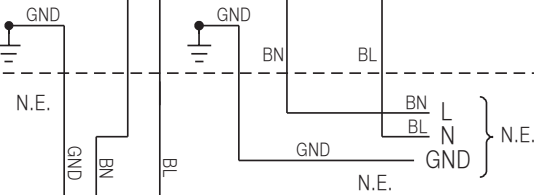
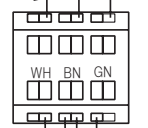

INPUT POWER 115V/1PH/60HZ

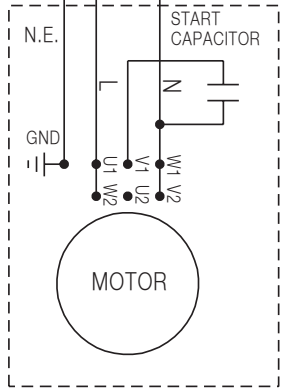

FAN MOTOR

NOTES:

- N.A. MOUNT ON DIN RAIL.
- N.B. MOUNT WITH SELF-TAPPING SCREWS ON MARKED MOUNTING HOLES PER INSTALLATION SECTION.
- N.C. TO INSERT CONDUCTORS IN TERMINAL BLOCK, PUSH IN ON FRONT OPENING WITH SMALL SCREWDRIVER, AND INSERT WIRE IN CORRESPONDING TOP OPENING.
- N.D. PLACE STICKER ON MOUNTING SURFACE BEHIND TERMINAL BLOCK SO THAT THE CENTERING LINES ALMOST COVER THE MOUNTING POINTS OF THE TERMINAL BLOCK.
- N.E. CONNECTIONS TO INPUT PLUG AND FAN MOTOR ARE INTERNAL TO THE MOBIFLEX BASE UNIT. STANDARD 115V PLUG AND 15 FT. (5M) INPUT CORD PROVIDED.
- N.F. LAMP WIRES ARE WHITE WITH BLACK SLEEVES.

S23315-2

MOBIFLEX 200-M



			
WARNING	<ul style="list-style-type: none"> Do not touch electrically live parts or electrode with skin or wet clothing. Insulate yourself from work and ground. 	<ul style="list-style-type: none"> Keep flammable materials away. 	<ul style="list-style-type: none"> Wear eye, ear and body protection.
Spanish AVISO DE PRECAUCION	<ul style="list-style-type: none"> No toque las partes o los electrodos bajo carga con la piel o ropa mojada. Aíslese del trabajo y de la tierra. 	<ul style="list-style-type: none"> Mantenga el material combustible fuera del área de trabajo. 	<ul style="list-style-type: none"> Protéjase los ojos, los oídos y el cuerpo.
French ATTENTION	<ul style="list-style-type: none"> Ne laissez ni la peau ni des vêtements mouillés entrer en contact avec des pièces sous tension. Isolez-vous du travail et de la terre. 	<ul style="list-style-type: none"> Gardez à l'écart de tout matériel inflammable. 	<ul style="list-style-type: none"> Protégez vos yeux, vos oreilles et votre corps.
German WARNUNG	<ul style="list-style-type: none"> Berühren Sie keine stromführenden Teile oder Elektroden mit Ihrem Körper oder feuchter Kleidung! Isolieren Sie sich von den Elektroden und dem Erdboden! 	<ul style="list-style-type: none"> Entfernen Sie brennbares Material! 	<ul style="list-style-type: none"> Tragen Sie Augen-, Ohren- und Körperschutz!
Portuguese ATENÇÃO	<ul style="list-style-type: none"> Não toque partes elétricas e electrodos com a pele ou roupa molhada. Isole-se da peça e terra. 	<ul style="list-style-type: none"> Mantenha inflamáveis bem guardados. 	<ul style="list-style-type: none"> Use proteção para a vista, ouvido e corpo.
Japanese 注意事項	<ul style="list-style-type: none"> ● 通電中の電気部品、又は溶材にヒフやぬれた布で触れないこと。 ● 施工物やアースから身体が絶縁されている様にして下さい。 	<ul style="list-style-type: none"> ● 燃えやすいものの側での溶接作業は絶対にしてはなりません。 	<ul style="list-style-type: none"> ● 目、耳及び身体に保護具をして下さい。
Chinese 警告	<ul style="list-style-type: none"> ● 皮肤或湿衣物切勿接触带电部件及焊条。 ● 使你自已与地面和工件绝缘。 	<ul style="list-style-type: none"> ● 把一切易燃物品移离工作场所。 	<ul style="list-style-type: none"> ● 佩戴眼、耳及身体劳动保护用具。
Korean 위험	<ul style="list-style-type: none"> ● 전도체나 용접봉을 젖은 헝겍 또는 피부로 절대 접촉치 마십시오. ● 모재와 접지를 접촉치 마십시오. 	<ul style="list-style-type: none"> ● 인화성 물질을 접근시키지 마십시오. 	<ul style="list-style-type: none"> ● 눈, 귀와 몸에 보호장구를 착용하십시오.
Arabic تحذير	<ul style="list-style-type: none"> ● لا تلمس الاجزاء التي يسري فيها التيار الكهربائي أو الألكترود بجلد الجسم أو بالملايس المبللة بالماء. ● وضع عازلا على جسمك خلال العمل. 	<ul style="list-style-type: none"> ● ضع المواد القابلة للاشتعال في مكان بعيد. 	<ul style="list-style-type: none"> ● ضع أدوات وملابس واقية على عينيك وأذنيك وجسمك.

READ AND UNDERSTAND THE MANUFACTURER'S INSTRUCTION FOR THIS EQUIPMENT AND THE CONSUMABLES TO BE USED AND FOLLOW YOUR EMPLOYER'S SAFETY PRACTICES.

SE RECOMIENDA LEER Y ENTENDER LAS INSTRUCCIONES DEL FABRICANTE PARA EL USO DE ESTE EQUIPO Y LOS CONSUMIBLES QUE VA A UTILIZAR, SIGA LAS MEDIDAS DE SEGURIDAD DE SU SUPERVISOR.

LISEZ ET COMPRENEZ LES INSTRUCTIONS DU FABRICANT EN CE QUI REGARDE CET EQUIPMENT ET LES PRODUITS A ETRE EMPLOYES ET SUIVEZ LES PROCEDURES DE SECURITE DE VOTRE EMPLOYEUR.

LESEN SIE UND BEFOLGEN SIE DIE BETRIEBSANLEITUNG DER ANLAGE UND DEN ELEKTRODENEINSATZ DES HERSTELLERS. DIE UNFALLVERHÜTUNGSVORSCHRIFTEN DES ARBEITGEBERS SIND EBENFALLS ZU BEACHTEN.

<ul style="list-style-type: none"> • Keep your head out of fumes. • Use ventilation or exhaust to remove fumes from breathing zone. 	<ul style="list-style-type: none"> • Turn power off before servicing. 	<ul style="list-style-type: none"> • Do not operate with panel open or guards off. 	WARNING
<ul style="list-style-type: none"> • Los humos fuera de la zona de respiración. • Mantenga la cabeza fuera de los humos. Utilice ventilación o aspiración para gases. 	<ul style="list-style-type: none"> • Desconectar el cable de alimentación de poder de la máquina antes de iniciar cualquier servicio. 	<ul style="list-style-type: none"> • No operar con panel abierto o guardas quitadas. 	Spanish AVISO DE PRECAUCION
<ul style="list-style-type: none"> • Gardez la tête à l'écart des fumées. • Utilisez un ventilateur ou un aspirateur pour ôter les fumées des zones de travail. 	<ul style="list-style-type: none"> • Débranchez le courant avant l'entretien. 	<ul style="list-style-type: none"> • N'opérez pas avec les panneaux ouverts ou avec les dispositifs de protection enlevés. 	French ATTENTION
<ul style="list-style-type: none"> • Vermeiden Sie das Einatmen von Schweißrauch! • Sorgen Sie für gute Be- und Entlüftung des Arbeitsplatzes! 	<ul style="list-style-type: none"> • Strom vor Wartungsarbeiten abschalten! (Netzstrom völlig öffnen; Maschine anhalten!) 	<ul style="list-style-type: none"> • Anlage nie ohne Schutzgehäuse oder Innenschutzverkleidung in Betrieb setzen! 	German WARNUNG
<ul style="list-style-type: none"> • Mantenha seu rosto da fumaça. • Use ventilação e exaustão para remover fumo da zona respiratória. 	<ul style="list-style-type: none"> • Não opere com as tampas removidas. • Desligue a corrente antes de fazer serviço. • Não toque as partes elétricas nuas. 	<ul style="list-style-type: none"> • Mantenha-se afastado das partes moventes. • Não opere com os painéis abertos ou guardas removidas. 	Portuguese ATENÇÃO
<ul style="list-style-type: none"> ● ヒュームから頭を離すようにして下さい。 ● 換気や排煙に十分留意して下さい。 	<ul style="list-style-type: none"> ● メンテナンス・サービスに取りかかる際には、まず電源スイッチを必ず切して下さい。 	<ul style="list-style-type: none"> ● パネルやカバーを取り外したまま機械操作をしないで下さい。 	Japanese 注意事項
<ul style="list-style-type: none"> ● 頭部遠離煙霧。 ● 在呼吸區使用通風或排風器除煙。 	<ul style="list-style-type: none"> ● 維修前切斷電源。 	<ul style="list-style-type: none"> ● 儀表板打開或沒有安全罩時不準作業。 	Chinese 警告
<ul style="list-style-type: none"> ● 얼굴로부터 용접가스를 멀리하십시오. ● 호흡지역으로부터 용접가스를 제거하기 위해 가스제거기나 통풍기를 사용하십시오. 	<ul style="list-style-type: none"> ● 보수전에 전원을 차단하십시오. 	<ul style="list-style-type: none"> ● 판넬이 열린 상태로 작동치 마십시오. 	Korean 위험
<ul style="list-style-type: none"> ● ابعء رأسك بعيداً عن الدخان. ● استعمل التهوية أو جهاز ضغط الدخان للخارج لكي تبعد الدخان عن المنطقة التي تتنفس فيها. 	<ul style="list-style-type: none"> ● اقطع التيار الكهربائي قبل القيام بأية صيانة. 	<ul style="list-style-type: none"> ● لا تشغيل هذا الجهاز اذا كانت الاغطية الحديدية الواقية ليست عليه. 	Arabic تحذير

LEIA E COMPREENDA AS INSTRUÇÕES DO FABRICANTE PARA ESTE EQUIPAMENTO E AS PARTES DE USO, E SIGA AS PRÁTICAS DE SEGURANÇA DO EMPREGADOR.

使う機械や溶材のメーカーの指示書をよく読み、まず理解して下さい。そして貴社の安全規定に従って下さい。

請詳細閱讀並理解製造廠提供的說明以及應該使用的銀焊材料，並請遵守貴方的有閣勞動保護規定。

이 제품에 동봉된 작업지침서를 숙지하시고 귀사의 작업자 안전수칙을 준수하시기 바랍니다.

اقرأ بتمعن وافهم تعليمات المصنع المنتج لهذه المعدات والمواد قبل استعمالها واتبع تعليمات الوقاية لصاحب العمل.



• World's Leader in Welding and Cutting Products •

• Sales and Service through Subsidiaries and Distributors Worldwide •

Cleveland, Ohio 44117-1199 U.S.A. TEL: 216.481.8100 FAX: 216.486.1751 WEB SITE: www.lincolnelectric.com